



The EBB Design extractor fans are suitable for many domestic and commercial ventilation applications where higher system resistance pressures are encountered. The EBB Design models incorporate a forward curved centrifugal impeller with single phase motor 230V-50Hz and Class II insulation (□). Maximum operating temperature 40°C.



Back draft shutter
The EBB Design are fitted with an automatic back draft shutter to prevent air entry and limit heat leakage when the extractor is not operating.



Forward curved centrifugal impeller
To deliver high performance with a minimum noise level against high static pressure system resistance.

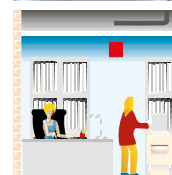

EXAMPLES OF INSTALLATION

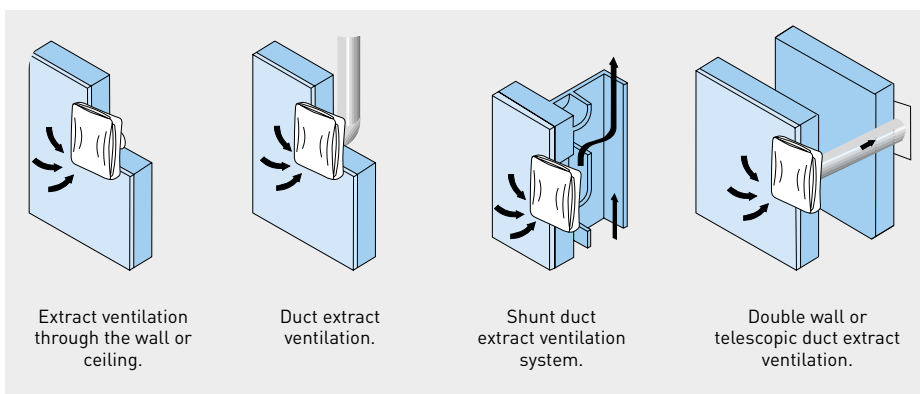

FEATURES

	S	M	T	HM	DV
BALL BEARINGS	•	•	•	•	•
BACKDRAFT SHUTTER	•	•	•	•	•
ON/OFF PULL CORD SWITCH		•		•	•
ONE SPEED MOTOR	•	•	•		
TWO SPEED MOTOR				•	•
UNSTABLE RUN-ON-TIMER (FROM 1 TO 30 MIN)			•		
ADJUSTABLE HUMIDISTAT 60-90 RH%				•	
WIRING DIAGRAM*	2, 3	11	4, 5	4, 5, 11	11

* See section of Wiring Diagrams.

TECHNICAL CHARACTERISTICS

Model	Speed (rpm)	Abs. power at free discharge (W)	Voltage (V) 50Hz	Sound pressure level* (dB(A))	Airflow at free discharge (m³/h)	IP	Weight (kg)
EBB-175 DESIGN	1250	26	230	41	155	Class II / IP44	2,20
	930	17		33	80		
EBB-250 DESIGN	1920	72	230	51	250	Class II / IP44	2,20
	1380	47		43	175		

* Sound pressure level measured at 1,5 m at free air conditions.

DIMENSIONS (mm)

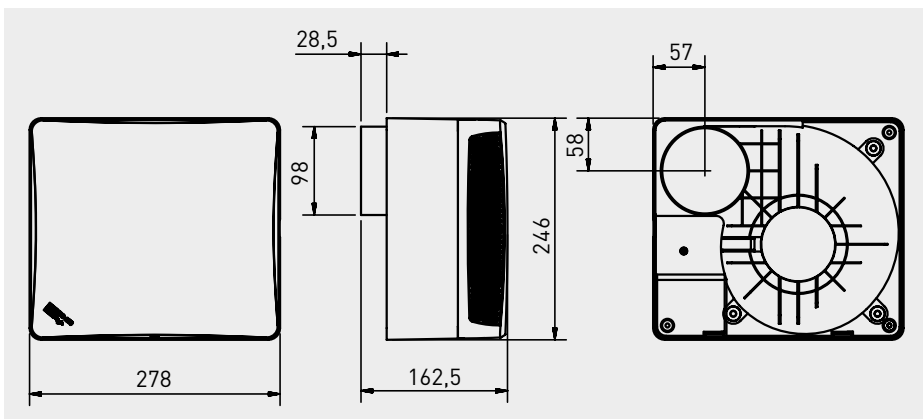

PERFORMANCE CURVE

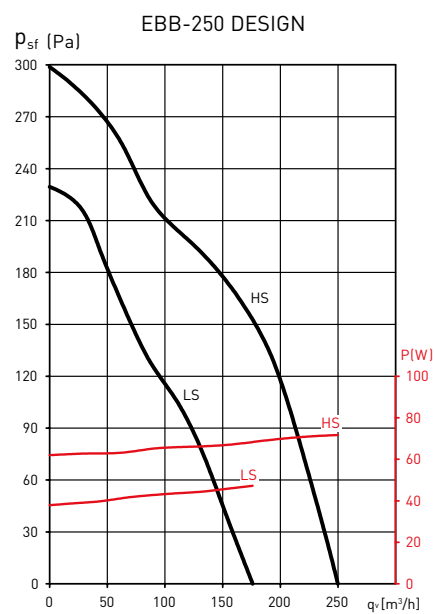
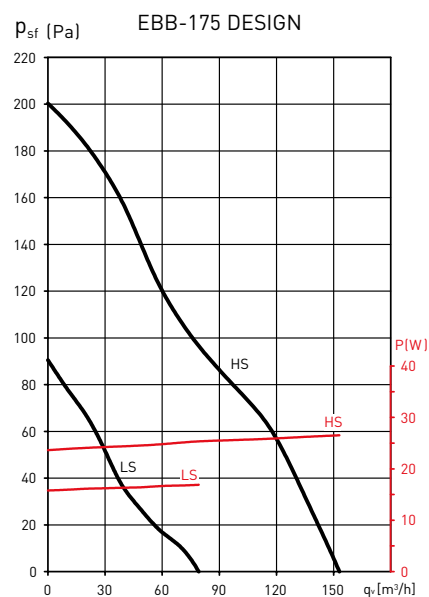

* 2 speed motors only for HM and DV models.

ACCESSORIES



GSA-100
Flexible aluminium ducting.



GRA-75
Aluminium external grille.



MRT-100
Circular duct joining piece.



CX-80/125
Worm drive ducting clip.



REB
Single phase electronic speed controllers.